

DESCRIPTION		
23 METRE ALUMINIUM PASSENGER CATAMARAN GENERAL ARRANGEMENT		
SCALE 1 : 60	SHEET 1 OF 1	DVG NO 6221G
DATE 5 FEB 15	DRAWN P.A.B.	FILE SC23GANZ4
DATE 2 DEC 16	UPDATED H.D.S	FILE FJ GAD16

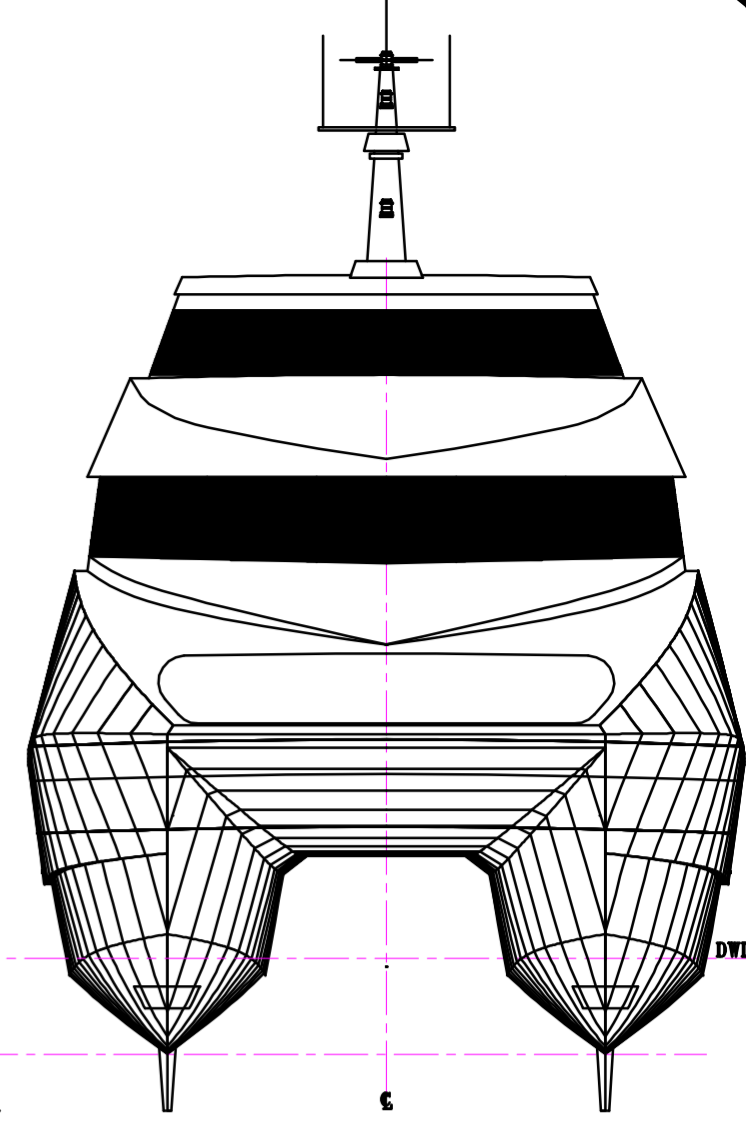

PROFILE

All stations spaced at 800 mm

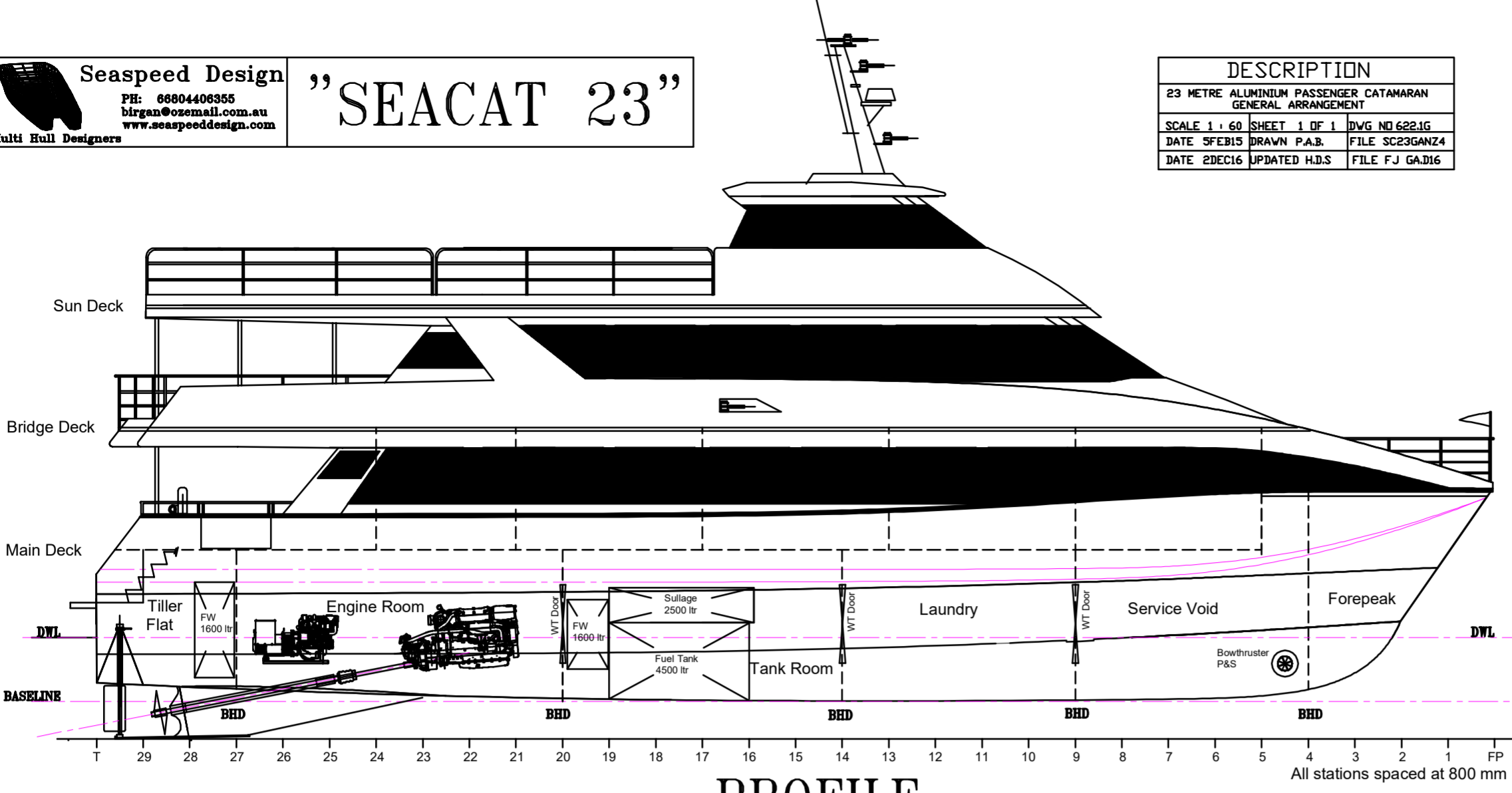
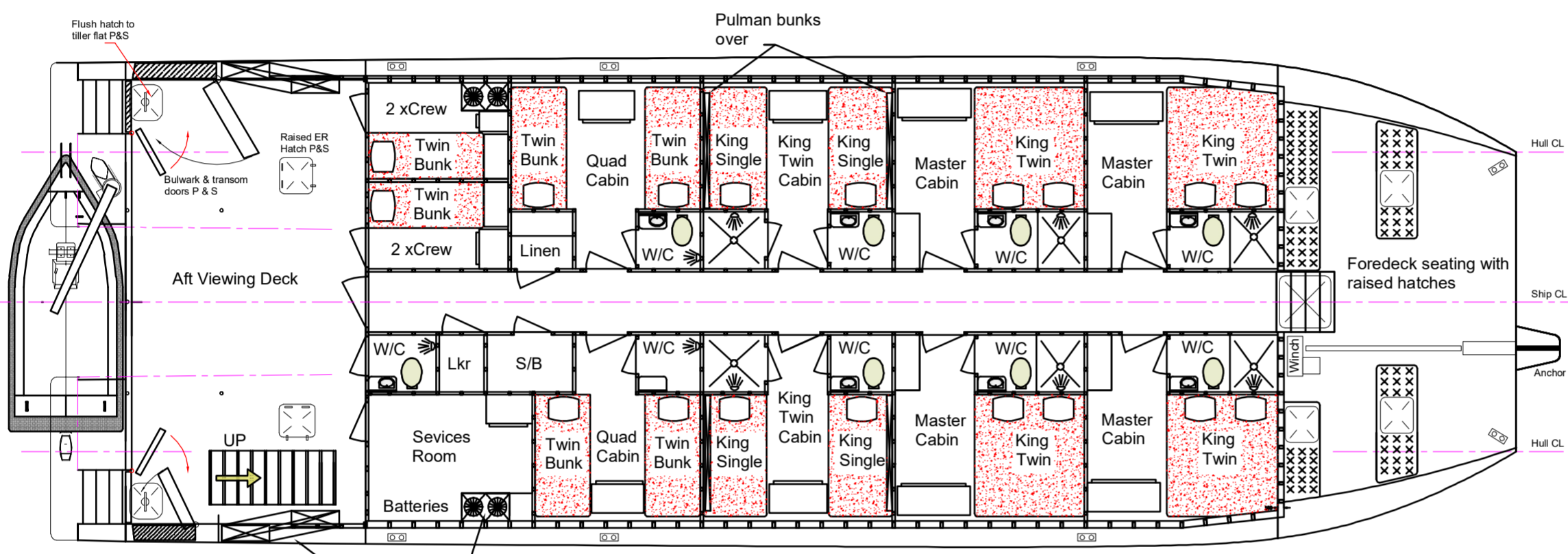

MAIN DECK PLAN

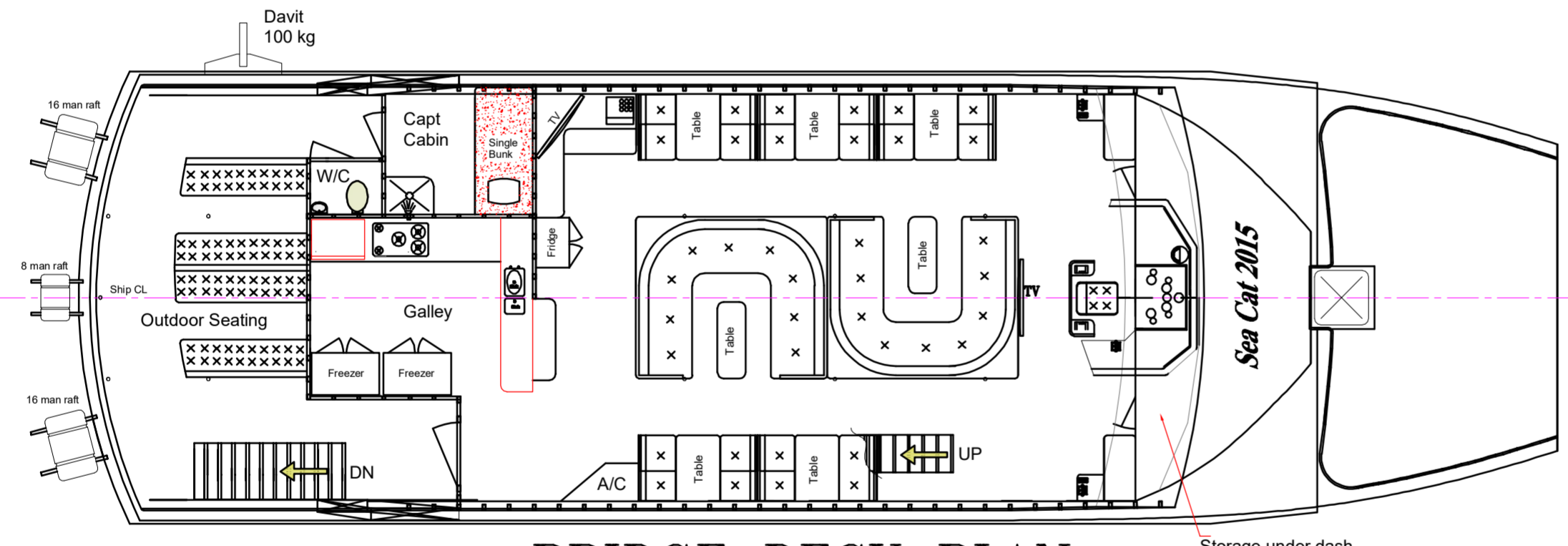

BRIDGE DECK PLAN

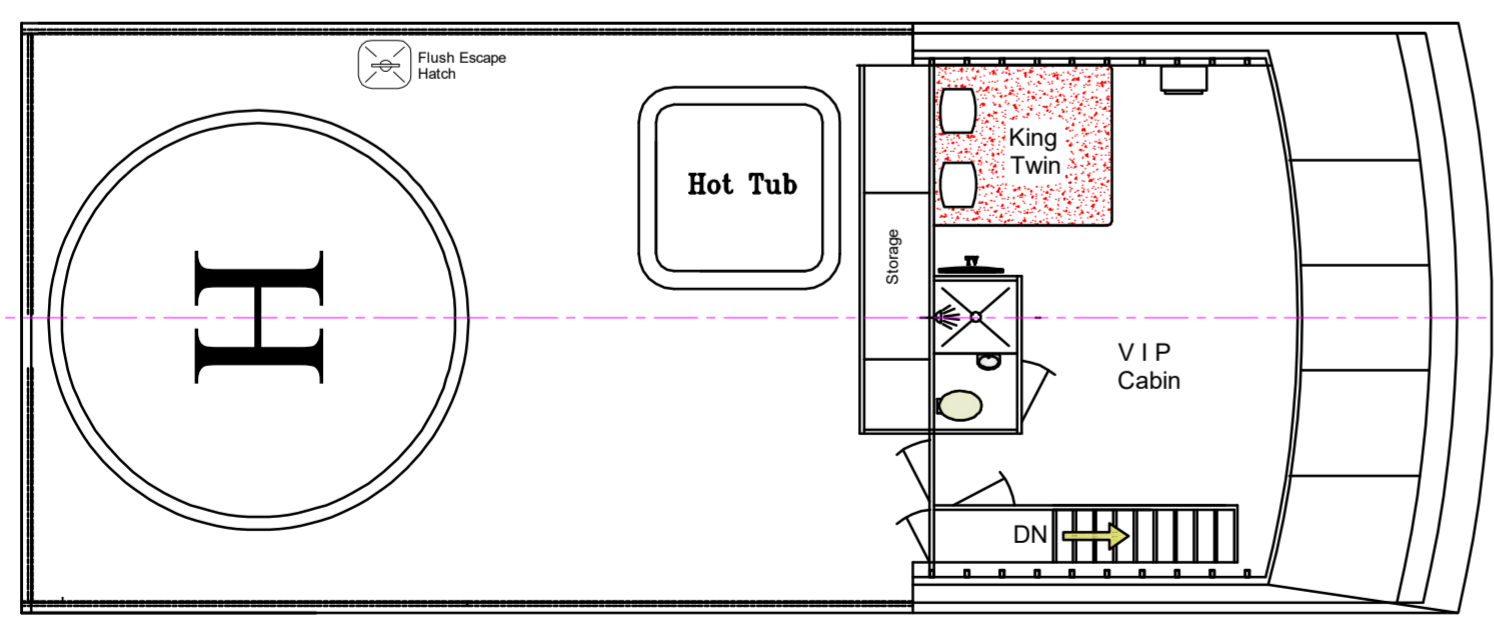

SUN DECK PLAN

PRINCIPAL PARTICULARS

LENGTH (LWL)	22.46 m
LENGTH (LOA)	23.97 m
BEAM	8.00 m
DEPTH	2.52 m
DRAFT (LOADED)	2.05 m
F.O.	2 X 4500 ltr
F.W.	2 X 1600 ltr
SULLAGE	2 X 1600 ltr
SPEED (LOADED)	16 KNOTS
DISPLACEMENT (LOADED)	80.0 tonne
WATERTIGHT COMPT.	12
PASSENGERS	20 BERTHED PAX
PASSENGERS	50 DAY PAX
CREW	5 MAX

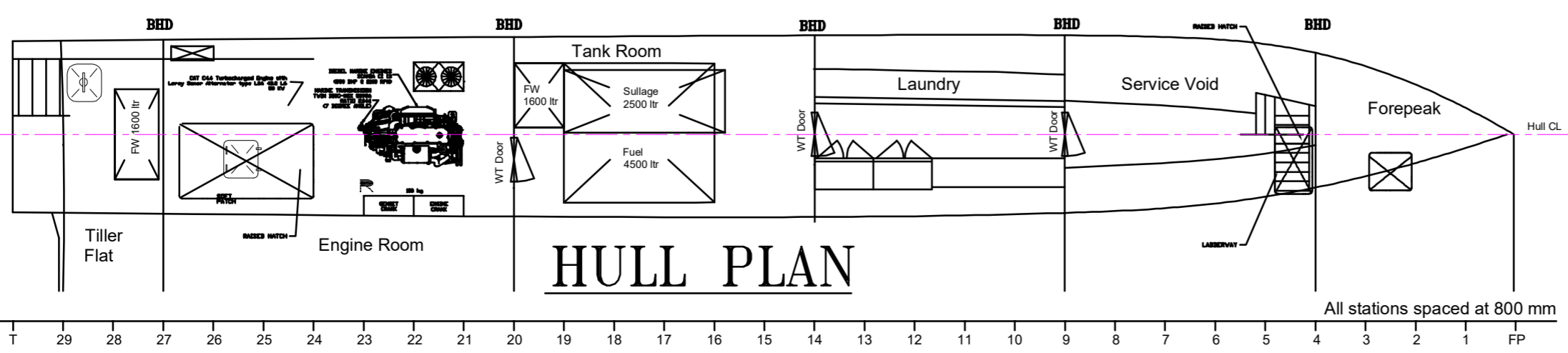

HULL PLAN

All stations spaced at 800 mm

FIORDLAND JEWEL